

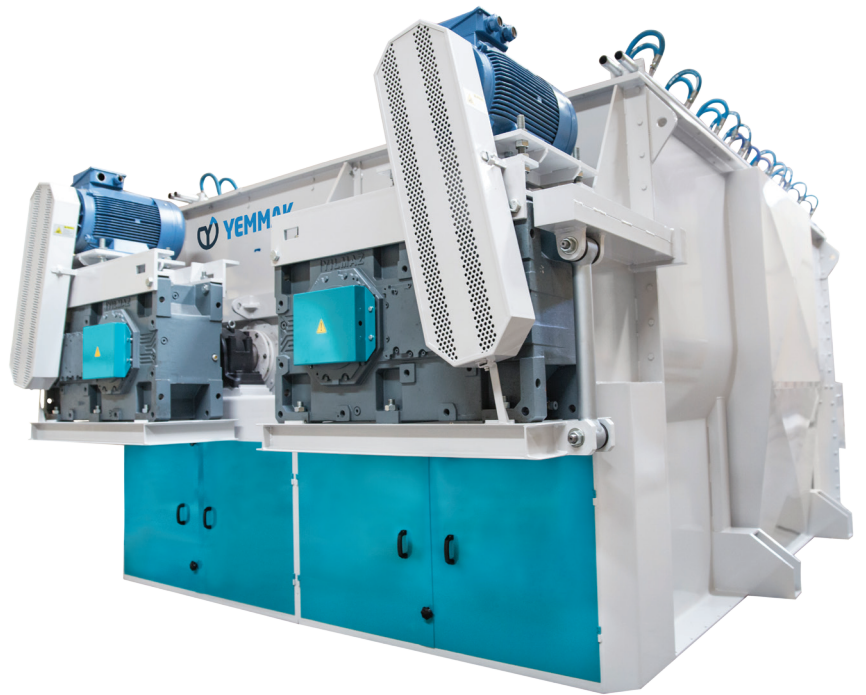

# DOUBLE SHAFT RIBBON PADDLE MIXER

## FEATURES

- High capacity range
- Low investment, operational and maintenance costs
- Maximum flexibility and variety
- 100% Safe maintenance hatches
- Locking system for hatches in case of power outage
- Wide selection of alternatives for liquid additives
- Sturdy build and standard dust pipe
- Auxillary parts and customer service



LIVESTOCK



POULTRY



FISH



PETS



FOOD



CHEMICALS

 **YEMMAK**

## DOUBLE SHAFT RIBBON PADDLE MIXER

Double Shaft Ribbon Paddle Mixer is designed to homogenously mix variety of free flowing grinded materials with or without added liquids. The mix is prepared with 1 in 100,000 sensitivity. With the help of dual shafts, the total mixing time drops below two minutes.

Intake time is reduced by wide pneumatic hatch while the output is also reduced by end to end openable dual hatches. The saved time ensures higher capacity/hour values.

## USAGE AREAS

- Feed production facilities
- Flour factories
- Chemical facilities
- Premix facilities

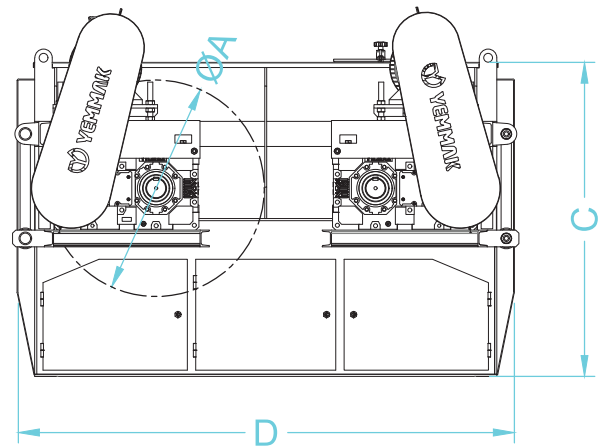
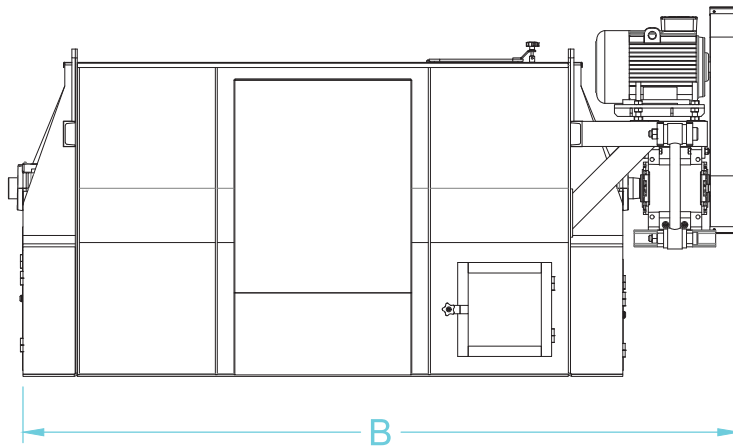
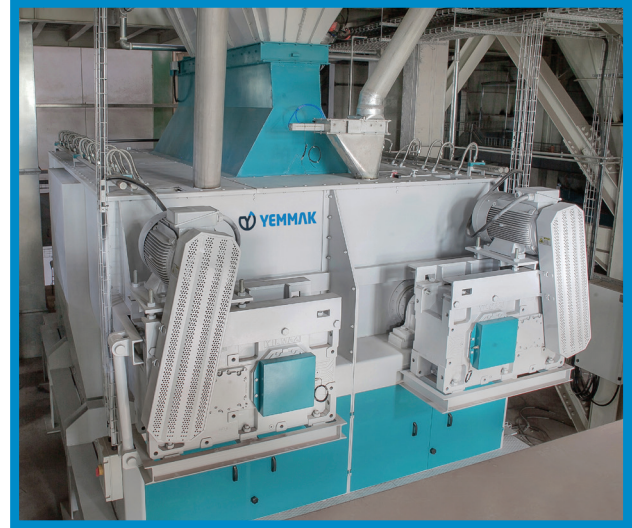

MODEL	CAPACITY		DIMENSIONS (mm)				MOTOR (kW)	RPM (rpm)
	dm <sup>3</sup>	kg	ØA	B	C	D		
RPDS 3000	3000	1500	1045	3497	1500	2211	18,5x2 22x2	32-34
RPDS 8000	8000	4000	1512	5466	2185	3172	30x2 37x2	20-22
RPDS 12000	12000	6000	1566	5484	2300	3292	37x2 45x2	20-22
RPDS 16000	16000	9000	1823	6400	2700	3826	55x2 75x2	18-20

600 Evler Mah. Balıkesir Asf. Sol Taraf No: 96, 10201 Bandırma / Balıkesir

P: +90 266 733 83 63 (3 Lines) • F: +90 266 733 83 66

[f](#) [in](#) [ig](#) [yt](#) | yemmak.com

